



Customer Service

1. Town of Bluffton updated their building permit forms, we will no longer accept the outdated versions beginning August 1st 2022.
2. To schedule inspections, please call 843-706-4500 do not send inspection requests via email.
3. Continue to re-call in inspections if they have failed for paperwork only. If we are not made aware of the re-inspection, the failure will not be cleared up.
4. CSS portal – How to View Inspection Reports & Upload Documents according to Town of Bluffton formatting requirements (see handout).
5. Residential building plans (larger plan set copy) is required to have all pages numbered at time of drop off or prior to issuance.
6. Final subcontractor rosters are requested at time of permanent service or at time of building final for verification. Failure to provide or notify Customer Service if uploaded to the portal will result in delay of obtaining CO.
7. FINAL elevation certificates in a zone other than X OR C are required to submit a hard copy and must have a raised seal stamp for review and approval.
8. Ice and Water Shield Affidavits must be sent to the inspections email or dropped off in person with the specifications included for review.
9. Revisions must include (3) new set of plans or updated pages; revision form and original inspector copy for submission.
10. Inspection cut off time over the phone and on the CSS portal is 4pm.

In the event of a severe storm and/or Hurricane, those that stay for restoration/remodels will be required to pull permits at the Law Enforcement Center (101 Progressive Street). All contractors are required to send Liz Trujillo (ltrujillo@townofbluffton.com) an updated list of all current team members that need to be included in the contractor distribution emails for any building & safety updates.

How to view Inspection Reports in CSS:

Under the permit, select the inspections tab.

Click the INSP- # hyperlink based on the Inspection Type (Description)

Dashboard Home Apply My Work Today's Inspections Map Report Pay Invoices Search Calendar

Permit Number: RNEW-09-21-3187

Permit Details | Tab Elements | Main Menu

| | | | | | |
|--------------|-----------------------------|---------------|----------------|-----------------|------------------------|
| Type: | New Single Family Residence | Status: | Issued | Project Name: | PALMETTO BLUFF PHASE 1 |
| IVR Number: | 130032 | Applied Date: | 09/27/2021 | Issue Date: | 10/15/2021 |
| District: | Palmetto Bluff | Assigned To: | | Expire Date: | 09/26/2022 |
| Square Feet: | 8,393.00 | Valuation: | \$3,290,000.00 | Finalized Date: | |
| Description: | PUD | | | | |

Summary Locations Fees Reviews **Inspections** Attachments Contacts Sub-Records

Progress 38% Completed

Workflow

- Issue Permit - Passed
- Residential Structure Review - Passed: 10/15/2021
- Subcontractor Review - Failed: 10/15/2021

Available Actions

- Failed Inspection: Residential Exterior Sheathing Fa [Reschedule]
- Request Inspection [Request]

| | | | | | |
|--------------|-----------------------------|---------------|----------------|-----------------|------------------------|
| Type: | New Single Family Residence | Status: | Issued | Project Name: | PALMETTO BLUFF PHASE 1 |
| IVR Number: | 130032 | Applied Date: | 09/27/2021 | Issue Date: | 10/15/2021 |
| District: | Palmetto Bluff | Assigned To: | | Expire Date: | 09/26/2022 |
| Square Feet: | 8,393.00 | Valuation: | \$3,290,000.00 | Finalized Date: | |
| Description: | PUD | | | | |

Summary Locations Fees Reviews **Inspections** Attachments Contacts Sub-Records

Existing Inspections | Request Inspections | Optional Inspections | Next Tab | Permit Details | Main Menu

Existing Inspections

Sort Description

| View Inspection | Description | Status | Request Date | Scheduled Date | Inspector | Action |
|----------------------------------|---|--------|--------------|----------------|----------------|--------|
| INSP-228775-2022 | Residential Exterior Sheathing Fastenings | Failed | 04/14/2022 | 04/18/2022 | Holland Sidney | |
| INSP-222336-2022 | Residential slab | Passed | 01/07/2022 | 01/07/2022 | Story Jon | |
| INSP-222209-2022 | Residential slab | Failed | 01/06/2022 | 01/06/2022 | Story Jon | |

Select: checklist tab to view **inspector comments**

Inspection Number: INSP-228775-2022

[Inspection Details](#) | [Tab Elements](#) | [Main Menu](#)

| | | | | | |
|--------------------|----------------------------------|-----------------|----------------|-----------------|------------|
| Inspection Type: | R - Exterior Sheathing Fastening | Requested Date: | 04/14/2022 | Requested Time: | |
| Inspection Status: | Failed | Scheduled Date: | 04/18/2022 | Completed Date: | 04/18/2022 |
| Permit Number: | RNEW-09-21-3187 | Inspector Name: | Sidney Holland | Completed Time: | |
| Main Address: | | | | | |

- Locations
- Contacts
- Checklist**
- Fees
- Attachments
- Previous

[Locations](#) | [Next Tab](#) | [Inspection Details](#) | [Main Menu](#)

Locations

Type: Location Address
115

Inspection Number: INSP-228775-2022

[Inspection Details](#) | [Tab Elements](#) | [Main Menu](#)

| | | | | | |
|--------------------|----------------------------------|-----------------|----------------|-----------------|------------|
| Inspection Type: | R - Exterior Sheathing Fastening | Requested Date: | 04/14/2022 | Requested Time: | 01:34 PM |
| Inspection Status: | Failed | Scheduled Date: | 04/18/2022 | Completed Date: | 04/18/2022 |
| Permit Number: | RNEW-09-21-3187 | Inspector Name: | Sidney Holland | Completed Time: | 5:21 PM |
| Main Address: | | | | | |

- Locations
- Contacts
- Checklist**
- Fees
- Attachments
- Previous

[Checklist](#) | [Next Tab](#) | [Inspection Details](#) | [Main Menu](#)

Checklist

Sort: Checklist Item

| Checklist Item | Description | Passed | Comments | Order |
|----------------|-------------|--------|---|-------|
| Other | Comments | No | 4/18/22 SH No stamped prints on site Inspection discontinued | 1 |



Uploading Documents in CSS:

Step 1 : Select the permit to upload documents to

Dashboard Home Apply My Work Today's Inspections Map Report Pay Invoices Search Calendar

Permit Number: RNEW-04-21-1238

Permit Details | Tab Elements | Main Menu

| | | | | | |
|--------------|--|---------------|----------------|-----------------|------------------------|
| Type: | New Single Family Residence | Status: | Issued | Project Name: | PALMETTO BLUFF PHASE 1 |
| IVR Number: | 127427 | Applied Date: | 04/26/2021 | Issue Date: | 06/07/2021 |
| District: | Palmetto Bluff | Assigned To: | | Expire Date: | 05/18/2022 |
| Square Feet: | 7,537.00 | Valuation: | \$2,650,000.00 | Finalized Date: | |
| Description: | Construction of New Single Family House with an attached Garage and whole home generator. Second floor is an open-webbed truss system. | | | | |

Summary Locations Fees Reviews Inspections Attachments Contacts Sub-Records More Info

Progress

33% Completed

- Completed
- In Progress
- Not Started

Workflow

- Issue Permit - Passed
- Residential Structure Review - Passed: 06/04/2021
- Inspection - R - Underground Plumbing - Passed: 08/11/2021
- Inspection - R - Temporary Service - Passed: 08/11/2021

Available Actions

- Failed Inspection: Residential Footing Inspection [Reschedule]
- Failed Inspection: Residential Exterior Sheathing Fa [Reschedule]
- Request Inspection

Step 2 : Select attachments tab









| Residence | | PHASE 1 | | | |
|---------------------|--|----------------------|----------------|------------------------|------------|
| IVR Number: | 127427 | Applied Date: | 04/26/2021 | Issue Date: | 06/07/2021 |
| District: | Palmetto Bluff | Assigned To: | | Expire Date: | 05/18/2022 |
| Square Feet: | 7,537.00 | Valuation: | \$2,650,000.00 | Finalized Date: | |
| Description: | Construction of New Single Family House with an attached Garage and whole home generator. Second floor is an open-webbed truss system. | | | | |

- Summary
- Locations
- Fees
- Reviews
- Inspections 1
- Attachments**
- Contacts
- Sub-Records
- More Info

[Attachments](#) | [Next Tab](#) | [Permit Details](#) | [Main Menu](#)

Attachments

Sort Needs Action ▾

| | | | |
|---|---|---|---|
|  Attachment Dyess - HVAC Mechanical Cert-Robinson.pdf Uploaded: 04/26/2021 Notes: HVAC Certificate |  Attachment Coast - Plumbing Mechanical Cert-Robinson.pdf Uploaded: 04/26/2021 Notes: Plumbing Certificate |  Attachment Robinson Bluffton Permit App for Submitting-signed.pdf Uploaded: 04/26/2021 Notes: Residential Building Application |  Attachment Generator Specs.pdf Uploaded: 04/26/2021 Notes: Building Plans |
|  |  |  |  |

Step 3: Click “Add Attachment”

Note:

- There is drop down menu to select from. Inspectors **DO NOT** review for paperwork based on these drop-down category options.
- Therefore, **PRIOR** to uploading a file – the document must be renamed to follow Town of Bluffton format guidelines:
“PERMIT NUMBER DOCUMENT NAME”

Example:

1238 Flashing Affidavit
1238 Roof & Shingles Cert
1238 HVAC Certificate

Do not include miscellaneous information such as homeowners name or lot numbers

If you have multiple permit numbers – you may include:

1238.1239.1240 Flashing Affidavit

However, it is contractor’s responsibility for uploading document(s) to **ALL** permit numbers associated with paperwork.

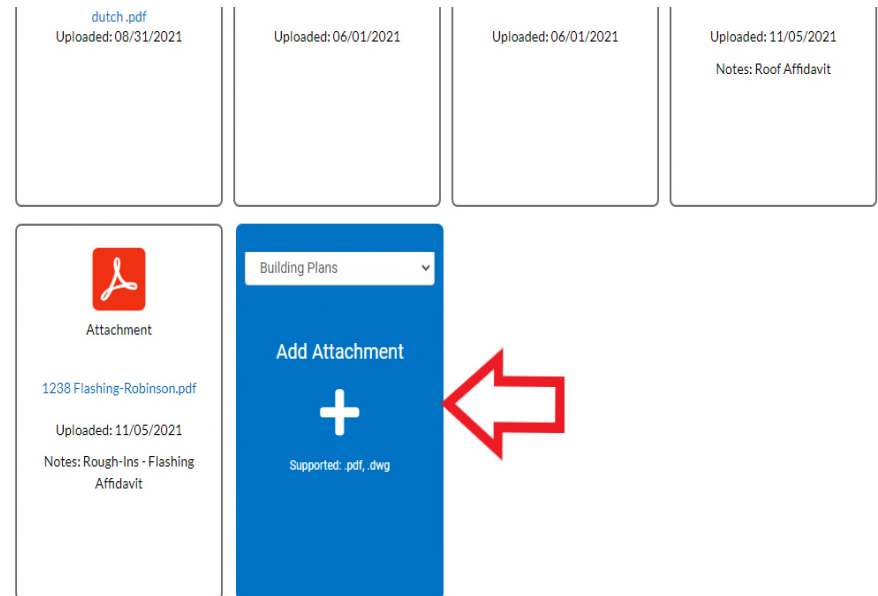

Step 5 :
Click
“Submit”
to Save
Changes

Building Plans ▾

Add Attachment

+

Supported: .pdf, .dwg



Submit

Need assistance or have a question? Please contact our Customer Service Department at 843-706-4500 or send us an [e-mail](#).





Watershed Management

1. Every home built in the Town of Bluffton requires a Stormwater Permit. Please contact the Town's Watershed Management Division (Lidia Delhomme ldelhomme@townofbluffton.com or Christina Hurd churd@townofbluffton.com) if you have questions on whether you are required to apply for an Individual Lot Stormwater Permit or are already covered by the Developer's Primary Permit.

Note: Developers have the right to terminate their primary permits at their own discretion. Stay connected with the developers and Watershed Management so you can plan accordingly.

2. Contact Andrea Moreno if you have any questions @ amoreno@townofbluffton.com or 843-706-7805.



Business License

1. Any company operating in the Town of Bluffton and obtaining monetary payments must have a Town of Bluffton Business License.
2. If the subcontractor is a 1099 employee-they require their own individual Business License
3. If the subcontractor is a W2 employee- they are covered by the GC Business License
4. Subcontractors cannot supervise a separate subcontractor per state law and LLR
5. If a subcontractor does not have a bond on file, they cannot exceed \$5000 worth of work.
6. Subcontractors with no LLR can only work for a **Commercially Licensed contractor** (GC or Mechanical Contractors)
7. If you have any questions, reach out to the Town of Bluffton Business License Department, (Kristy Carge) kcarge@townofbluffton.com or (Hannah Hartberger) hhartberger@townofbluffton.com or 843-706-4501.

Sec. 5-271. – Construction Site Property Maintenance.

A. All construction sites shall be maintained in a good, clean and safe condition, including, but not limited to, the following minimum requirements: 1. Handling of debris. Accumulated construction debris shall be hauled away and disposed of in accordance with all applicable laws, on a regular basis, but no less than one (1) time per week. Any debris temporarily stored on site must be stored and secured so as to prevent a safety risk or danger. In addition to any applicable dumpster requirements set forth in this Code, dumpsters shall be emptied or removed when full. Debris from construction sites shall not be disposed of in dumpsters located at any other construction site within the Town without the prior approval of the Chief Building Official, or designee.

2. Storage of construction materials. Construction materials shall be stored, maintained and secured so as to prevent safety risk or danger. Except as otherwise provided herein, construction materials shall not be stored in a right-of-way.

3. Site cleanliness. All mud, dirt or debris deposited on any street, alley, lane, crosswalk, sidewalk or other public property as a result of demolition, excavation or construction shall be removed and cleaned on a regular basis, and at all times when a nuisance has been created by said debris. In addition, such areas shall be broom cleaned to the extent possible at the end of each day that construction work has occurred. Debris shall be disposed of in accordance with all applicable laws.

4. Portable toilets. A portable toilet shall be provided at every construction site of a new principal structure, or addition thereto, prior to the commencement of construction, unless an existing facility is available on the site. Portable toilets shall be located to have the least possible impact on adjacent properties and should be located, to the extent possible, at the rear of the construction site and out of plain view of any public right-of-way. Portable toilets shall be serviced no less than once a week.

5. Ingress and egress. Routes of access for ingress and egress to the construction site, which will provide protection to pedestrians and minimize disruption of traffic and damage to the public rights-of-way, shall be followed. The Town reserves the right to designate certain prescribed routes of access for construction traffic.

6. Oversized construction vehicles. Oversized construction vehicles will be allowed only on those streets or rights-of-way as designated by the Town Manager or designee

7. Tree protection measures. All trees and other vegetation on the public right of-way shall be protected from damage by means of appropriate fencing. Fencing around trees on the public right-of-way shall be placed so as to protect the critical root zone, which is that circular area under the tree as determined by a one-foot radius for each one-inch in diameter. All tree protection measures set forth in any approved tree protection plans must also be followed.

8. Utilities and on-site equipment. On-site electricity is required for construction-related work as soon as is practicable. The proposed locations of any generator and/or compressor shall be depicted on the plans submitted at the time of application for the review and approval of the Town, and shall be located so as to have the least possible impact on adjacent properties, preferably at the rear of the property.

9. Use of public property. No loading, unloading, or storage of demolition debris, spoil or construction materials shall be permitted within any right-of-way, on any public property or within ten (10) feet of

any right-of-way adjacent to public or private property, unless specifically approved by the Town and shown on an approved Development Plan, if applicable. Sec.

5-272. – Preparation of Construction Sites and Developed Sites for Severe Weather Events

A. Intent. The provisions of this Section apply at the direction of the Town Manager, or designee, in the event of significant severe weather conditions, or other similar types of severe weather warnings for any part of Beaufort County.

B. Construction sites.

1. All construction materials, including roof tiles, within the Town shall be secured, stored or removed so as not to create a safety hazard because of hurricane or tropical storm force winds, or similar severe weather.

2. Media broadcasts or notices issued by the National Weather Service or National Hurricane Center of a hurricane or tropical storm warning shall be deemed sufficient notice to the owner of real property upon which construction is occurring or any contractor responsible for the construction to secure, store or remove loose construction debris and loose construction materials against the effects of high wind.

3. Materials stockpiled on top of any structure under construction shall be permanently installed by the property owner or contractor at the direction of the Town Manager, or designee. However, if such installation cannot be timely completed, then the property owner or contractor shall: **a.** Band together the construction materials and mechanically fasten them to the top of the structure in such a manner so a threat of becoming airborne during a tropical storm or hurricane is not experienced; **b.** Remove the construction materials from the top of the structure and mechanically tie them down to the ground; **c.** Remove the construction materials from the job site; or **d.** Store the construction materials inside a protected structure.

4. Interiors of structures under construction shall be secured to prevent materials from becoming airborne.

5. All debris on a construction site shall be stored in commercial containers and shall be properly secured.

6. Commercial containers and portable toilets must be removed from a construction site or mechanically tied to the ground.

7. Piles of dirt, sand, and stone on a construction site shall be located away from rights-of way, adjoining properties, swales, culverts, inlet grates, creeks, coves and rivers.

8. All construction materials or debris required to be secured, stored or removed shall remain secure, stored or removed hereunder from the property until the National Weather Service, National Hurricane Center or other appropriate weather agency has removed all portions of Beaufort County from those areas included in a hurricane or tropical storm warning, or the Town Manager, or designee, lifts a severe weather directive pursuant to this Section, whichever event shall first occur.

FLOOR

Allowable Holes:
 Trus Joist® TJI® Joists 1
 TJI® Joist Nailing
 Requirements at Bearing 2
 Installation Recommendations 2
 TJI® Joist Floor Framing 3
 Fastening of Floor Panels 3
 Rim Board Details and Installation 4
 Floor Details 4-5
 Cantilever Details 5
 Filler and Backer Blocks 5
 Web Stiffeners 6
 Framing Connectors 8

ROOF AND WALL

Allowable Holes:
 Trus Joist® TimberStrand® LSL
 Wall Studs 2
 Web Stiffeners 6
 Typical Roof and Wall Framing 6
 Ceiling Joists 6
 Roof Details 7
 Framing Connectors 8
 Shear Blocking and Ventilation Holes . . 8
 TJI® Joist Nailing
 Requirements at Bearing 8

BEAM AND COLUMN

Allowable Holes:
 Trus Joist® TimberStrand® LSL,
 Parallam® PSL, Microllam® LVL
 Headers and Beams 2
 Beam and Column Details 9
 Beam and Header Bearings 9

BUILD SAFELY

We at Weyerhaeuser are committed to working safely and want to remind you to do the same. We encourage you to follow the recommendations of OSHA (www.osha.gov) in the U.S. or provincial regulations (www.canoshweb.org/en/) in Canada regarding:

- Personal protective equipment (PPE) for hands, feet, head, and eyes
- Fall protection
- Use of pneumatic nailers and other hand tools
- Forklift safety

Please adhere to the Weyerhaeuser product installation details, including the installation of safety bracing on unsheathed floors and roofs.

PRODUCT IDENTIFICATION

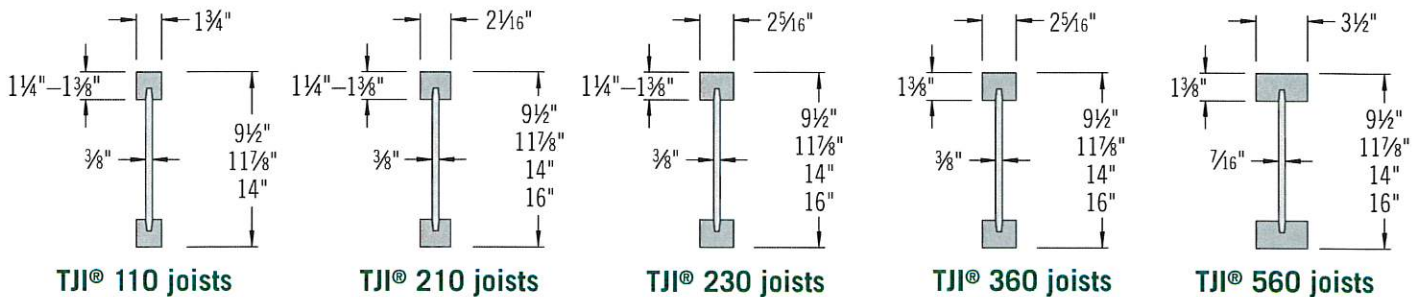

ALLOWABLE HOLES—TJI® JOISTS

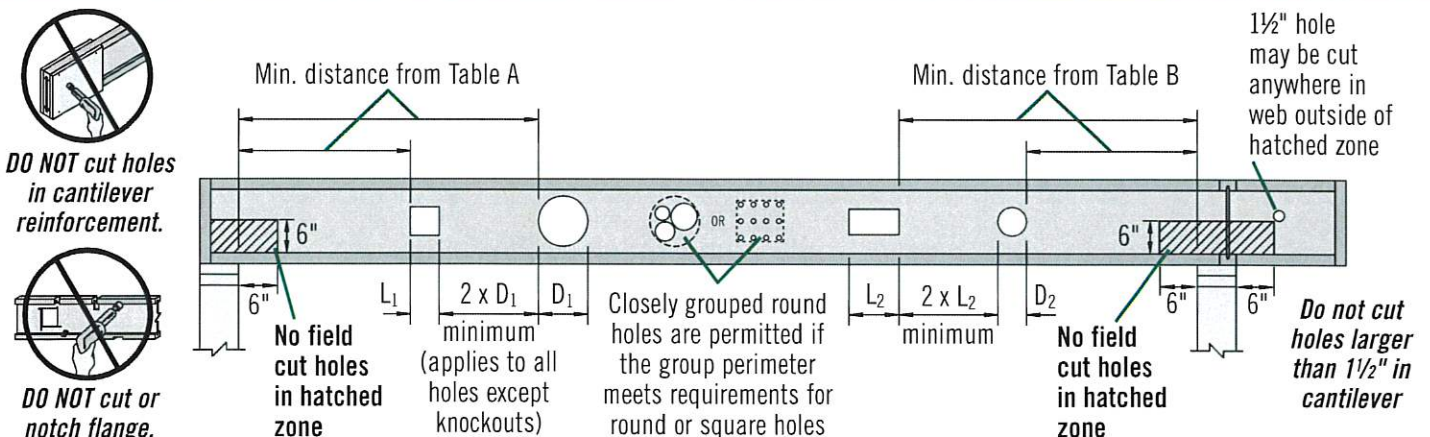

Table A—End Support

Minimum distance from edge of hole to inside face of nearest end support

| Joist Depth | TJI® | Round Hole Size | | | | | | | Square or Rectangular Hole Size | | | | | | |
|-------------|------|-----------------|-------|-------|-------|-------|-------|--------|---------------------------------|-------|-------|-------|--------|--------|--------|
| | | 2" | 3" | 4" | 6½" | 8⅞" | 11" | 13" | 2" | 3" | 4" | 6½" | 8⅞" | 11" | 13" |
| 9½" | 110 | 1'-0" | 1'-6" | 2'-0" | 5'-0" | | | | 1'-0" | 1'-6" | 2'-6" | 4'-6" | | | |
| | 210 | 1'-0" | 1'-6" | 2'-6" | 5'-6" | | | | 1'-0" | 2'-0" | 2'-6" | 5'-0" | | | |
| | 230 | 1'-6" | 2'-0" | 2'-6" | 5'-6" | | | | 1'-0" | 2'-0" | 3'-0" | 5'-0" | | | |
| | 360 | 1'-6" | 2'-0" | 3'-0" | 6'-0" | | | | 1'-6" | 2'-6" | 3'-6" | 5'-6" | | | |
| | 560 | 1'-6" | 2'-6" | 3'-6" | 7'-0" | | | | 2'-0" | 3'-0" | 4'-0" | 6'-0" | | | |
| 11⅞" | 110 | 1'-0" | 1'-0" | 1'-6" | 2'-6" | 5'-6" | | | 1'-0" | 1'-6" | 2'-0" | 4'-6" | 6'-0" | | |
| | 210 | 1'-0" | 1'-6" | 2'-0" | 3'-0" | 6'-0" | | | 1'-0" | 1'-6" | 2'-6" | 5'-0" | 6'-6" | | |
| | 230 | 1'-0" | 1'-6" | 2'-0" | 3'-0" | 6'-6" | | | 1'-0" | 2'-0" | 2'-6" | 5'-6" | 7'-0" | | |
| | 360 | 1'-6" | 2'-0" | 3'-0" | 4'-6" | 7'-0" | | | 1'-6" | 2'-6" | 3'-6" | 6'-6" | 7'-6" | | |
| | 560 | 1'-6" | 2'-6" | 3'-0" | 5'-6" | 8'-0" | | | 2'-6" | 3'-6" | 4'-6" | 7'-0" | 8'-0" | | |
| 14" | 110 | 1'-0" | 1'-0" | 1'-0" | 1'-6" | 3'-0" | 5'-6" | | 1'-0" | 1'-0" | 1'-6" | 3'-6" | 6'-0" | 8'-0" | |
| | 210 | 1'-0" | 1'-0" | 1'-0" | 2'-0" | 3'-6" | 6'-0" | | 1'-0" | 1'-0" | 2'-0" | 4'-0" | 6'-6" | 8'-6" | |
| | 230 | 1'-0" | 1'-0" | 1'-0" | 2'-6" | 4'-0" | 7'-0" | | 1'-0" | 1'-0" | 2'-0" | 4'-0" | 7'-0" | 9'-0" | |
| | 360 | 1'-0" | 1'-0" | 1'-6" | 3'-6" | 5'-6" | 8'-0" | | 1'-0" | 1'-6" | 2'-6" | 6'-0" | 8'-0" | 9'-6" | |
| | 560 | 1'-0" | 1'-0" | 2'-0" | 4'-6" | 6'-6" | 9'-0" | | 1'-6" | 3'-0" | 4'-0" | 7'-0" | 9'-0" | 10'-0" | |
| 16" | 210 | 1'-0" | 1'-0" | 1'-0" | 1'-0" | 2'-6" | 3'-6" | 6'-0" | 1'-0" | 1'-0" | 1'-0" | 3'-0" | 6'-6" | 8'-0" | 11'-0" |
| | 230 | 1'-0" | 1'-0" | 1'-0" | 1'-6" | 3'-0" | 4'-0" | 7'-0" | 1'-0" | 1'-0" | 1'-0" | 3'-6" | 7'-0" | 9'-0" | 11'-0" |
| | 360 | 1'-0" | 1'-0" | 1'-0" | 2'-6" | 4'-6" | 6'-6" | 9'-0" | 1'-0" | 1'-0" | 1'-6" | 5'-0" | 9'-0" | 10'-0" | 11'-6" |
| | 560 | 1'-0" | 1'-0" | 1'-0" | 2'-6" | 5'-0" | 7'-6" | 10'-0" | 1'-0" | 2'-0" | 3'-0" | 6'-6" | 10'-0" | 11'-0" | 12'-0" |

Table B—Intermediate or Cantilever Support

Minimum distance from edge of hole to inside face of nearest intermediate or cantilever support

| Joist Depth | TJI® | Round Hole Size | | | | | | | Square or Rectangular Hole Size | | | | | | |
|-------------|------|-----------------|-------|-------|--------|--------|--------|--------|---------------------------------|-------|-------|--------|--------|--------|--------|
| | | 2" | 3" | 4" | 6½" | 8⅞" | 11" | 13" | 2" | 3" | 4" | 6½" | 8⅞" | 11" | 13" |
| 9½" | 110 | 2'-0" | 2'-6" | 3'-6" | 7'-6" | | | | 1'-6" | 2'-6" | 3'-6" | 6'-6" | | | |
| | 210 | 2'-0" | 2'-6" | 3'-6" | 8'-0" | | | | 2'-0" | 3'-0" | 4'-0" | 7'-6" | | | |
| | 230 | 2'-6" | 3'-0" | 4'-0" | 8'-6" | | | | 2'-0" | 3'-6" | 4'-6" | 7'-6" | | | |
| | 360 | 3'-0" | 4'-0" | 5'-6" | 9'-0" | | | | 3'-0" | 4'-6" | 5'-6" | 8'-0" | | | |
| | 560 | 3'-6" | 5'-0" | 6'-0" | 10'-0" | | | | 4'-0" | 5'-6" | 6'-6" | 9'-0" | | | |
| 11⅞" | 110 | 1'-0" | 1'-0" | 1'-6" | 4'-0" | 8'-6" | | | 1'-0" | 1'-6" | 2'-6" | 7'-0" | 9'-6" | | |
| | 210 | 1'-0" | 1'-0" | 2'-0" | 4'-6" | 9'-0" | | | 1'-0" | 2'-0" | 3'-0" | 8'-0" | 10'-0" | | |
| | 230 | 1'-0" | 2'-0" | 2'-6" | 5'-0" | 10'-0" | | | 1'-0" | 2'-6" | 3'-6" | 8'-6" | 10'-6" | | |
| | 360 | 2'-0" | 3'-0" | 4'-0" | 7'-0" | 11'-0" | | | 2'-0" | 3'-6" | 5'-0" | 9'-6" | 11'-0" | | |
| | 560 | 1'-6" | 3'-0" | 4'-6" | 8'-0" | 12'-0" | | | 3'-0" | 4'-6" | 6'-0" | 10'-6" | 12'-0" | | |
| 14" | 110 | 1'-0" | 1'-0" | 1'-0" | 2'-0" | 4'-6" | 8'-6" | | 1'-0" | 1'-0" | 1'-0" | 5'-0" | 9'-0" | 12'-0" | |
| | 210 | 1'-0" | 1'-0" | 1'-0" | 2'-6" | 5'-6" | 9'-6" | | 1'-0" | 1'-0" | 2'-0" | 6'-0" | 10'-0" | 13'-0" | |
| | 230 | 1'-0" | 1'-0" | 1'-0" | 3'-6" | 6'-0" | 10'-6" | | 1'-0" | 1'-0" | 2'-6" | 6'-6" | 11'-0" | 13'-6" | |
| | 360 | 1'-0" | 1'-0" | 2'-0" | 5'-6" | 8'-6" | 12'-6" | | 1'-0" | 2'-0" | 4'-0" | 9'-0" | 12'-0" | 14'-0" | |
| | 560 | 1'-0" | 1'-0" | 1'-6" | 5'-6" | 9'-6" | 13'-6" | | 1'-0" | 3'-0" | 5'-0" | 10'-0" | 13'-6" | 15'-0" | |
| 16" | 210 | 1'-0" | 1'-0" | 1'-0" | 1'-0" | 3'-6" | 6'-0" | 10'-0" | 1'-0" | 1'-0" | 1'-0" | 4'-6" | 10'-0" | 12'-6" | 16'-0" |
| | 230 | 1'-0" | 1'-0" | 1'-0" | 1'-6" | 4'-0" | 6'-6" | 11'-0" | 1'-0" | 1'-0" | 1'-0" | 5'-0" | 10'-6" | 13'-6" | 16'-6" |
| | 360 | 1'-0" | 1'-0" | 1'-0" | 3'-0" | 6'-6" | 10'-0" | 13'-6" | 1'-0" | 1'-0" | 2'-0" | 7'-6" | 13'-0" | 14'-6" | 17'-0" |
| | 560 | 1'-0" | 1'-0" | 1'-0" | 2'-6" | 7'-0" | 11'-0" | 15'-0" | 1'-0" | 1'-0" | 3'-6" | 9'-0" | 14'-6" | 16'-0" | 18'-0" |

- Leave ⅛" of web (minimum) at top and bottom of hole. **DO NOT cut joist flanges.**
- Tables are based on uniform load tables in current design literature.
- For simple span (5' minimum), uniformly loaded joists used in residential applications, one maximum size round hole may be located at the center of the joist span **provided that no other holes occur in the joist.**

TJI® JOIST NAILING REQUIREMENTS AT BEARING

TJI® Joist to Bearing Plate

1 1/8" TJI® Rim Board or 1/4" TimberStrand® LSL

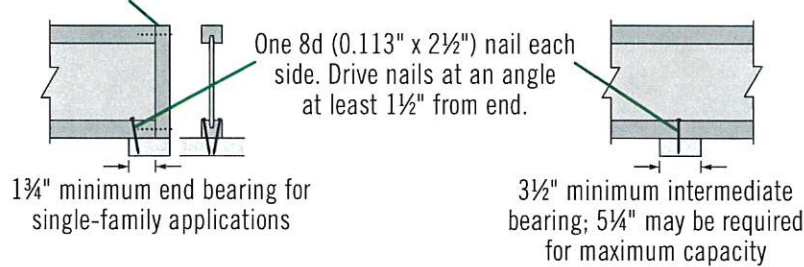

One 8d (0.113" x 2 1/2") nail each side. Drive nails at an angle at least 1 1/2" from end.

1 3/4" minimum end bearing for single-family applications

3 1/2" minimum intermediate bearing; 5 1/4" may be required for maximum capacity

- Increased bearing capacities may be achieved with increased bearing lengths. See plans for required bearing lengths.

Shear transfer nailing: Use connections equivalent to floor panel nailing schedule. See page 4.

Squash Blocks to TJI® Joist (Load bearing wall above)

One 10d (0.128" x 3") nail into each flange

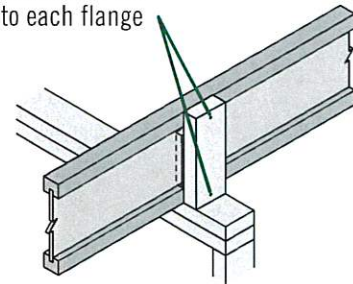

Also see detail B2, page 5

Rim to TJI® Joist

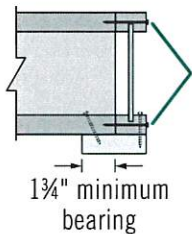

1 1/8" TJI® Rim Board, 1/4" TimberStrand® LSL, or TJI® 110 rim joist:

One 10d (0.131" x 3") nail into each flange

TJI® 210, 230, and 360 rim joist:

One 16d (0.135" x 3 1/2") nail into each flange

1 3/4" minimum bearing

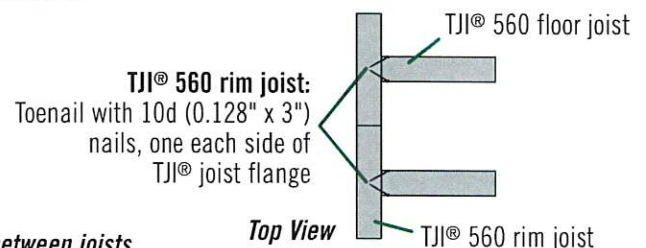

TJI® 560 rim joist:
Toenail with 10d (0.128" x 3") nails, one each side of TJI® joist flange

Top View

Locate rim board joint between joists

INSTALLATION RECOMMENDATIONS

RECOMMENDED COMPONENTS

- Weyerhaeuser Edge Gold™ floor panels
- TJI® joists
- 1 1/8" TJI® Rim Board or 1/4" TimberStrand® LSL

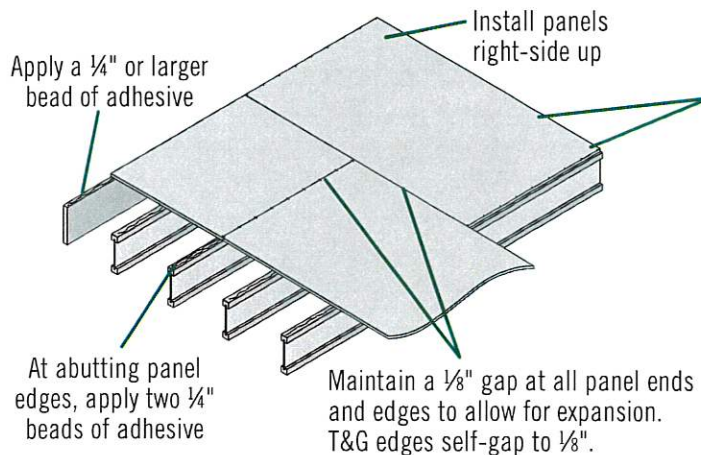

Apply a 1/4" or larger bead of adhesive

Install panels right-side up

At abutting panel edges, apply two 1/4" beads of adhesive

Maintain a 1/8" gap at all panel ends and edges to allow for expansion. T&G edges self-gap to 1/8".

RECOMMENDED ADHESIVES

- Weyerhaeuser recommends using solvent-based subfloor adhesives that meet ASTM D3498 (AFG-01) performance standards. When latex subfloor adhesive is required, careful selection is necessary due to a wide range of performance between brands.

Nail panel to joist at 12" on-center in field and 6" on-center along panel edges. Apply fasteners 3/8" from panel edges.

- For 3/4" panels, use 8d (0.131" x 2 1/2") or 6d (0.120" x 2") deformed-shank nails or other code-approved fasteners.
- For 7/8" panels, use 8d (0.131" x 2 1/2") or 8d (0.120" x 2 1/2") deformed-shank nails or other code-approved fasteners.
- Fully nail floor panel within 10 minutes of applying adhesive (or sooner if required by adhesive manufacturer).
- Screws may be substituted for the nails noted above if the screws have equivalent lateral load capacity.

1.55E TimberStrand® LSL Headers and Beams

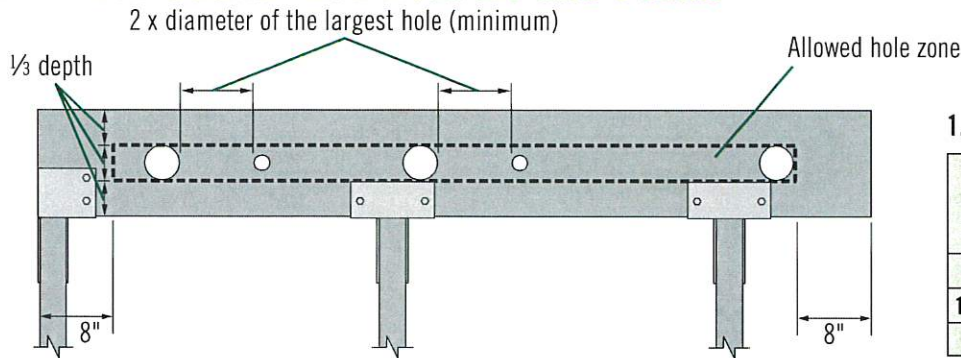

1.55E TimberStrand® LSL

| Header or Beam Depth | Maximum Round Hole Size |
|----------------------|-------------------------|
| 9¼"–9½" | 3" |
| 11¼"–11¾" | 3⅝" |
| 14"–16" | 4⅝" |

GENERAL NOTES

- Allowed hole zone suitable for headers and beams with **uniform and/or concentrated loads** anywhere along the member.
- Round holes only.
- No holes in headers or beams in plank orientation.

- See illustration for allowed hole zone.

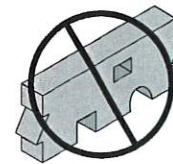

DO NOT cut, notch, or drill holes in headers or beams except as indicated in the illustrations and tables.

Other Trus Joist® Headers and Beams

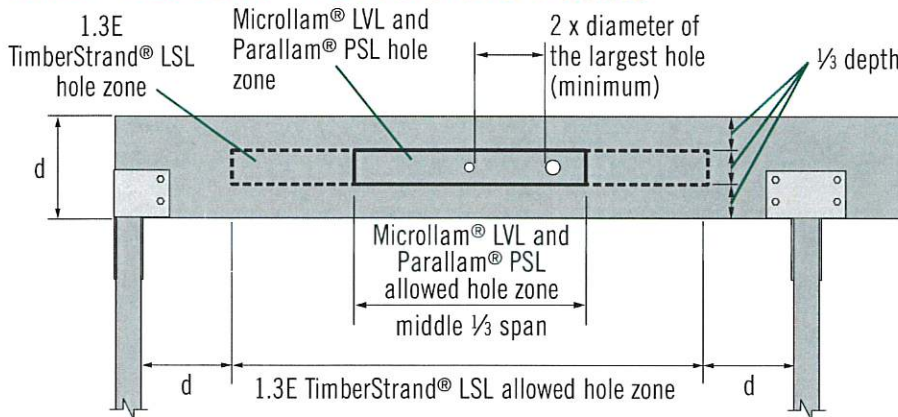

Other Trus Joist® Beams

| Header or Beam Depth | Maximum Round Hole Size |
|----------------------|-------------------------|
| 4⅜" | 1" |
| 5½" | 1¾" |
| 7¼"–20" | 2" |

GENERAL NOTES

- Allowed hole zone suitable for headers and beams with **uniform loads only**.
- No holes in cantilevers.
- Round holes only.
- No holes in headers or beams in plank orientation.

- See illustration for allowed hole zone.

TimberStrand® LSL Wall Studs

One notch may be cut anywhere except the middle ⅓ of the length of the stud or column. Holes may be drilled anywhere along the length of the stud or column but must be at least ⅝" from the edge.

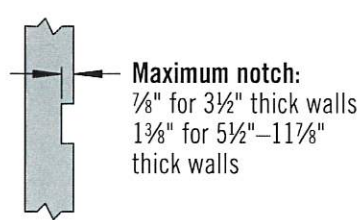
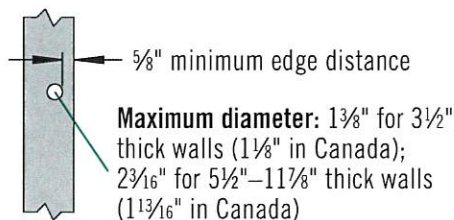

DO NOT cut a notch and a hole in the same cross section.

TJI® joist floor framing does not require bridging or mid-span blocking



DO NOT use sawn lumber for rim board or blocking as it may shrink after installation. Use only engineered lumber.

See Filler and Backer Blocks on page 5

Joists must be laterally supported at cantilever and end bearings by blocking panels, hangers, or direct attachment to a rim board or rim joist.

WARNING
Joists are unstable until laterally braced. See Warning on cover.

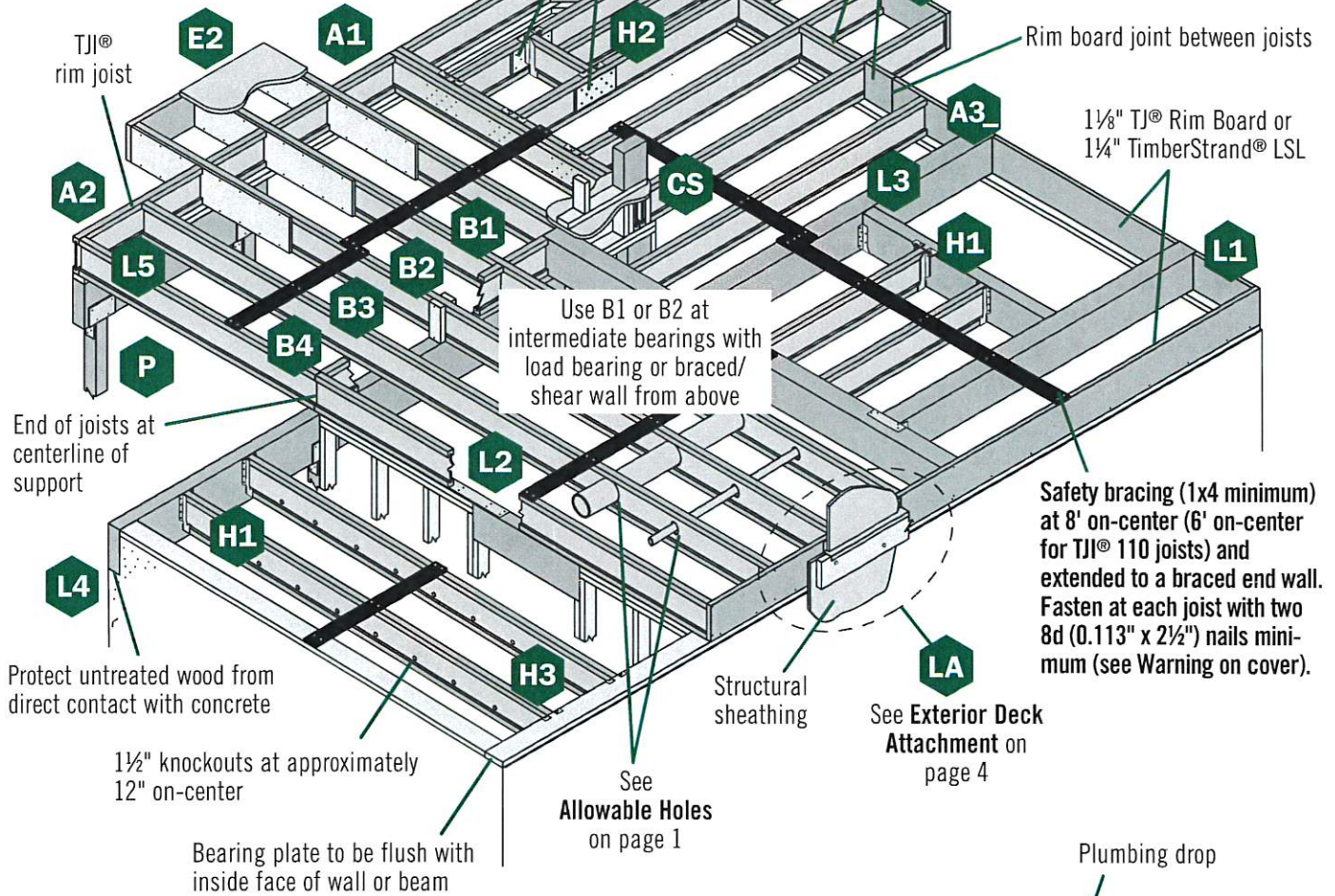

INSTALLATION TIPS

- Subfloor adhesive will improve floor performance, but may not be required.
- Squash blocks and blocking panels carry stacked vertical loads (details B1 and B2). Packing out the web of a TJI® joist (with web stiffeners) is not a substitute for squash blocks or blocking panels.
- When joists are doubled at non-load bearing parallel partitions, space joists apart the width of the wall for plumbing or HVAC.
- Additional joist at plumbing drop (see detail at right).

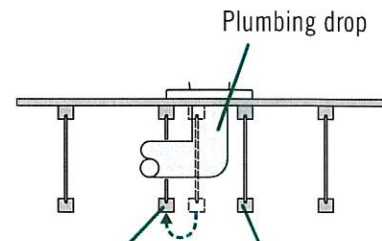

Joist may be shifted up to 3" if floor panel edge is supported and span rating is not exceeded. Do not cut joist flanges.

Additional joist is required if floor panel edge is unsupported or if span rating is exceeded.

FLOOR DETAILS

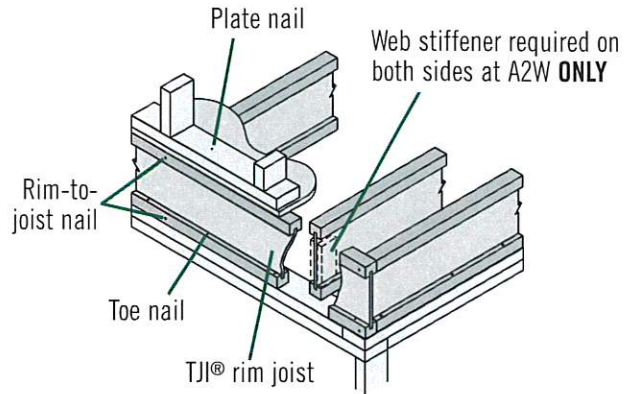
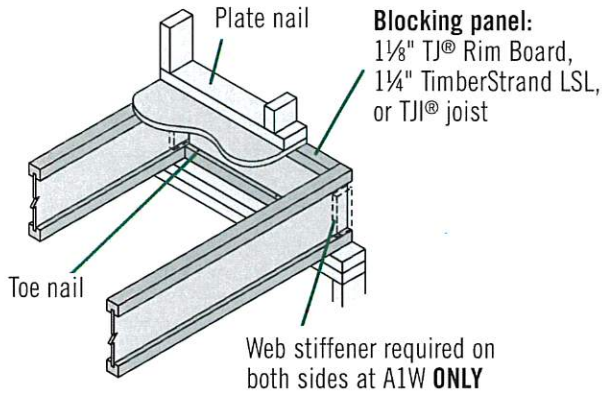

A1 A1 W Attach blocking per A3.1 in rim board installation table above

A2 A2 W Must have 1 1/4" minimum joist bearing at ends. Attach rim joist per A3.1 in rim board installation table above.

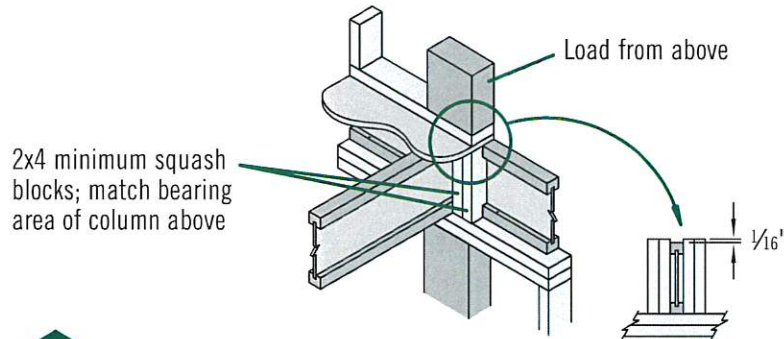

CS Use 2x4 minimum squash blocks to transfer load around TJI® joist

Exterior Deck Attachment

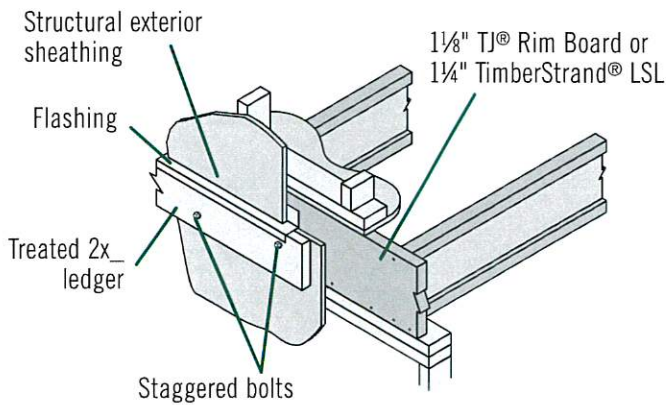

LA Corrosion-resistant fasteners required for wet-service applications

Shimmed Deck Attachment

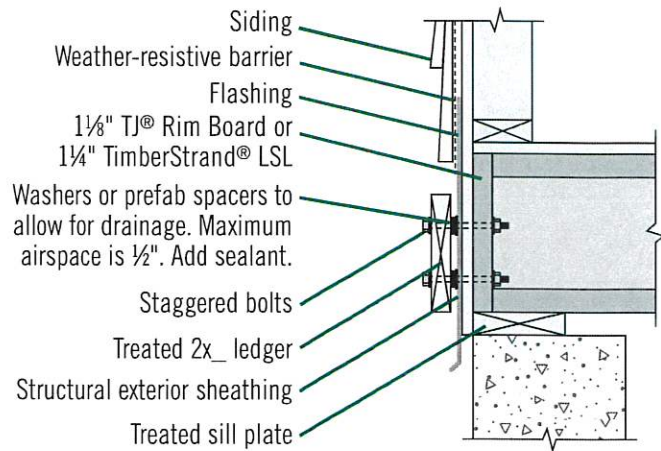

Maintain 2" distance (minimum) from edge of ledger to edge of fastener. Stagger bolts.

Load bearing or braced/shear wall above (must stack over wall below)

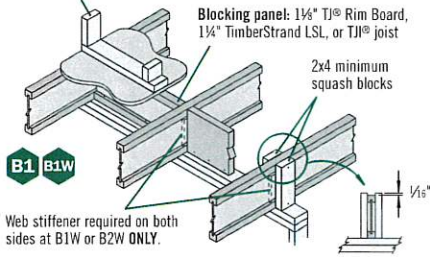

No load bearing wall above

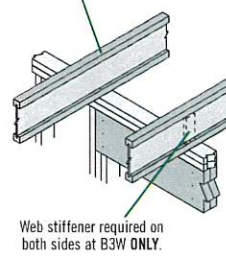

B2 B2W Blocking panels may be required with braced/shear walls above or below—see detail B1

B3 B3W Blocking panels may be required with braced/shear walls above or below—see detail B1

CANTILEVER DETAILS

At PB1, cantilever back span must be permanently braced with either direct-applied ceiling along entire length or permanent bracing at ½ points. See detail below for connections.

8" diameter maximum hole for 11¼"-16" deep blocking panels; 6" diameter maximum for blocking panels 9½" deep or shorter than 12" long. Do not cut flanges.

1¼" TJ® Rim Board or 1¼" TimberStrand® LSL closure, typical

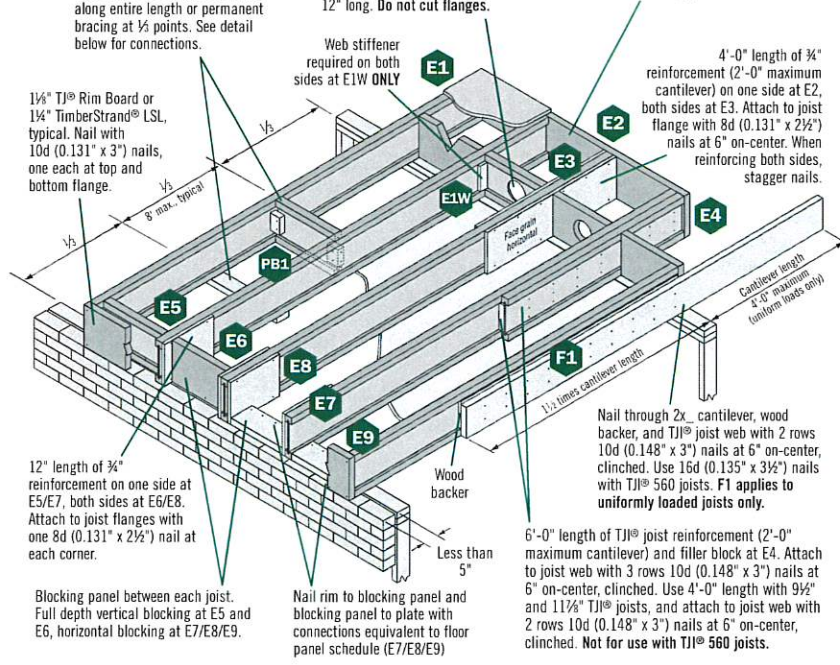

Two 2½" screws for 2x strapping connections

When specified on the layout, one of the bracing options shown at right is required

PB1

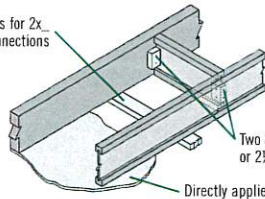

FILLER AND BACKER BLOCKS

HANGER BACKER BLOCK

Install tight to top flange (tight to bottom flange with face mount hangers).

- Single-Family Applications: Attach with ten 10d (0.128" x 3") nails, clinched when possible.
- Multi-Family Applications: Attach with fifteen 10d (0.128" x 3") nails, clinched when possible.

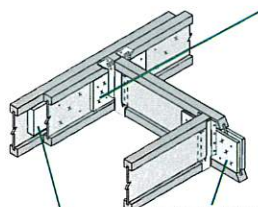

H2

DOUBLE TJ® JOIST FILLER BLOCK

- Single-Family Applications: Attach with ten 10d (0.128" x 3") nails, clinched. Use ten 16d (0.135" x 3½") nails from each side with TJ® 560 joists.
- Multi-Family Applications: Attach with fifteen 10d (0.128" x 3") nails, clinched. Use fifteen 16d (0.135" x 3½") nails from each side with TJ® 560 joists.

Filler and Backer Block Sizes

| TJ® | 110 | | 210 | | 230 or 360 | | 560 | |
|---|----------------|-----------------|-------------------------------|--------------------------------|-------------------------------|--------------------------------|----------------|------------|
| Depth | 9½" or 11¼" | 14" | 9½" or 11¼" | 14" or 16" | 9½" or 11¼" | 14" or 16" | 9½" or 11¼" | 14" or 16" |
| Filler Block ⁽¹⁾ (Detail H2) | 2x6 | 2x8 | 2x6 + ½" sheathing | 2x8 + ½" sheathing | 2x6 + ½" sheathing | 2x8 + ½" sheathing | Two 2x6 | Two 2x8 |
| Cantilever Filler (Detail E4) | 2x6 4'-0" long | 2x10 6'-0" long | 2x6 + ½" sheathing 4'-0" long | 2x10 + ½" sheathing 6'-0" long | 2x6 + ½" sheathing 4'-0" long | 2x10 + ½" sheathing 6'-0" long | Not applicable | |
| Backer Block ⁽¹⁾ (Detail F1 or H2) | ¾" or ¾" | | ¾" or ¾" | | ¾" or 1" net | | 2x6 | 2x8 |

(1) If necessary, increase filler and backer block height for face mount hangers and maintain ¼" gap at top of joist. See detail W. Filler and backer block dimensions should accommodate required nailing without splitting. The suggested minimum length is 24" for filler and 12" for backer blocks.

FILLER AND BACKER BLOCKS

HANGER BACKER BLOCK

Install tight to top flange (tight to bottom flange with face mount hangers).

- **Single-Family Applications:** Attach with ten 10d (0.128" x 3") nails, clinched when possible.
- **Multi-Family Applications:** Attach with fifteen 10d (0.128" x 3") nails, clinched when possible.

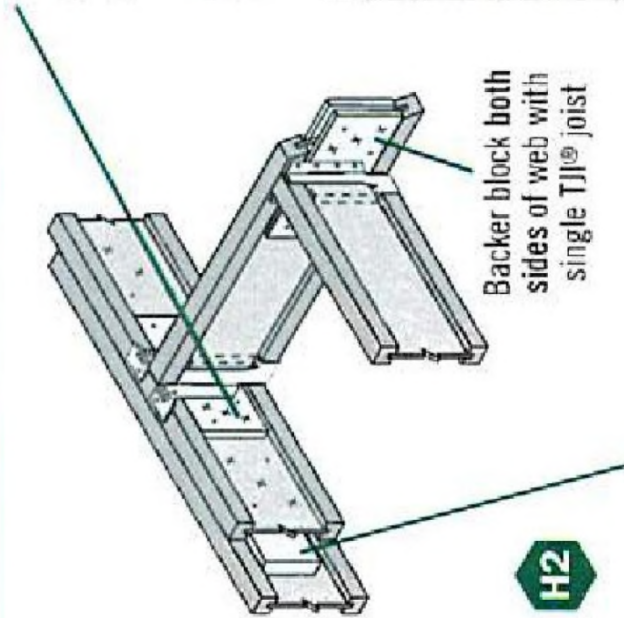

Filler and Backer Block Sizes

| TJI® | 110 | 210 | 230 or 360 | 560 |
|---|----------------|-------------------------------|-------------------------------|----------------|
| Depth | 9½" or 11½" | 14" or 16" | 9½" or 11½" | 9½" or 11½" |
| Filler Block ⁽¹⁾ (Detail H2) | 2x6 | 2x6 + ¾" sheathing | 2x6 + ½" sheathing | Two 2x6 |
| Cantilever Filler (Detail E4) | 2x6 4'-0" long | 2x5 + ¾" sheathing 4'-0" long | 2x6 + ½" sheathing 4'-0" long | Not applicable |
| Backer Block ⁽¹⁾ (Detail F1 or H2) | ¾" or ¾" | ¾" or ¾" | ½" or 1" net | 2x6 |

(1) If necessary, increase filler and backer block height for face mount hangers and maintain ¼" gap at top of joist. See detail W. Filler and backer block dimensions should accommodate required nailing without splitting. The suggested minimum length is 24" for filler and 12" for backer blocks.

DOUBLE TJI® JOIST FILLER BLOCK

- **Single-Family Applications:** Attach with ten 10d (0.128" x 3") nails, clinched. Use ten 16d (0.135" x 3½") nails from each side with TJI® 560 joists.
- **Multi-Family Applications:** Attach with fifteen 10d (0.128" x 3") nails, clinched. Use fifteen 16d (0.135" x 3½") nails from each side with TJI® 560 joists.

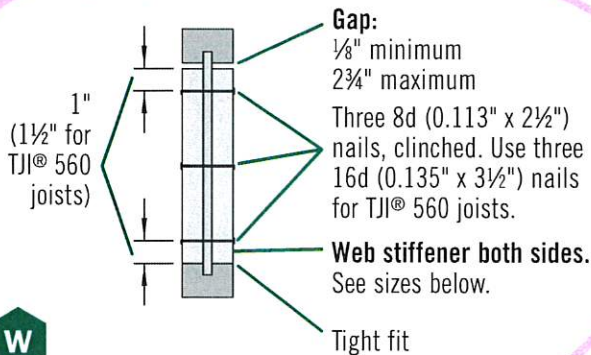

WEB STIFFENER SIZES

- TJI® 110 joists: 5/8" x 2 5/16" minimum⁽¹⁾
- TJI® 210 joists: 3/4" x 2 5/16" minimum⁽¹⁾
- TJI® 230 and 360 joists: 7/8" x 2 5/16" minimum⁽¹⁾
- TJI® 560 joists: 2x4, construction grade or better

(1) PS1 or PS2 sheathing, face grain vertical

WEB STIFFENER REQUIREMENTS

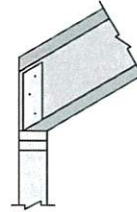

Required at all birdsmouth cuts.

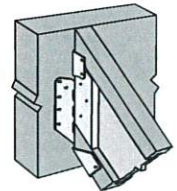

Required at all sloped hangers.



Required if the sides of the hanger do not extend to laterally support at least 3/8" of the TJI® joist top flange.

Only required at intermediate bearing locations when noted on framing plan.

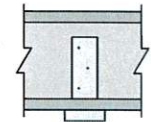

TYPICAL ROOF AND WALL FRAMING

DETAIL SCHEDULE

Roof details (see page 7)

- R1** on bevel plate
- R1 W** on bevel plate with web stiffeners
- R3** with variable slope seat connector
- R3 W** with seat connector and web stiffeners
- R5** with birdsmouth cut
- R7** intermediate bearing
- R7 W** intermediate bearing with web stiffeners

- R8** 2x4 outrigger and filler with birdsmouth cut
- R9** 2x4 outrigger without filler
- R10** 2x4 outrigger with filler
- R10 W** 2x4 outrigger with filler and web stiffeners
- R14** ridge detail
- R14 W** ridge detail, with web stiffeners

Other details

- O** 2x_ overhang at end wall
 - SB** shear blocking (see page 8)
 - W** web stiffeners
- ### Hanger details (see page 8)
- H5** slope adjusted hanger
 - H6** header on slope

Joists must be laterally supported at cantilever and end bearings by blocking panels, hangers, or direct attachment to a rim board or rim joist.